

# WATER TUBES

ITEM NO. CRW-WT-1000

TYPE "A"

(Use with Telescoping Tubes  
Type "B" & "C")

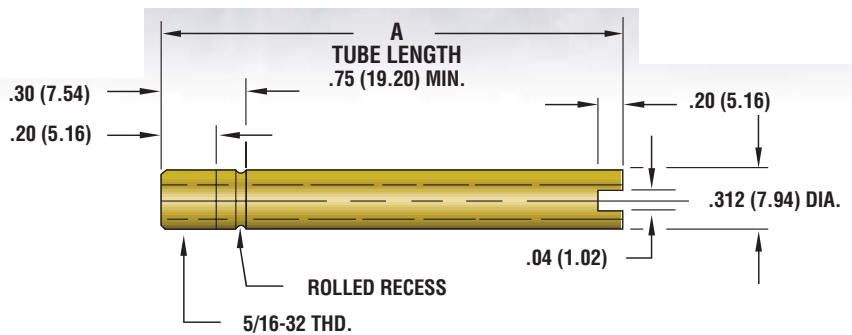

FIGURE 7-1 (Material - 1/4 ID BRASS TUBE)

ITEM NO. CRW-WT-1200

TYPE "B"

(Use with 4 RW Electrodes)

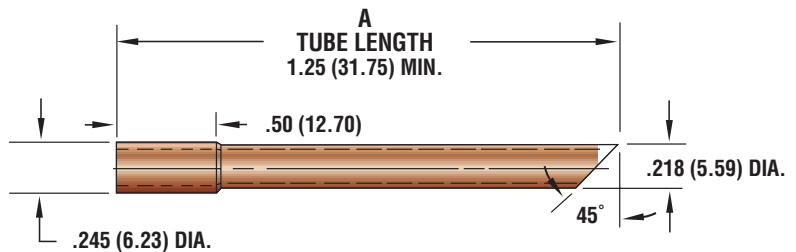

FIGURE 7-2 (Material - Copper)

ITEM NO. CRW-WT-1300

TYPE "C"

(Use with 5, 6 & 7 RW Electrodes)

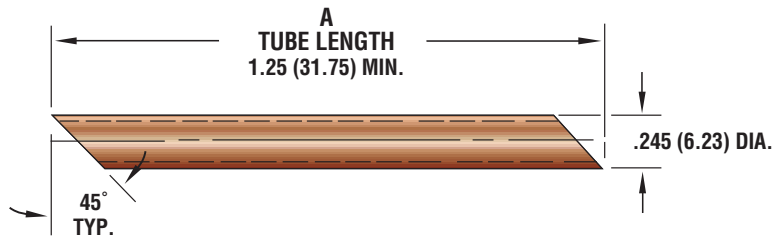

FIGURE 7-3 (Material - Copper)

ITEM NO. CRW-WT-1400

TYPE "D"

(Use with 5, 6 & 7 RW Electrodes)

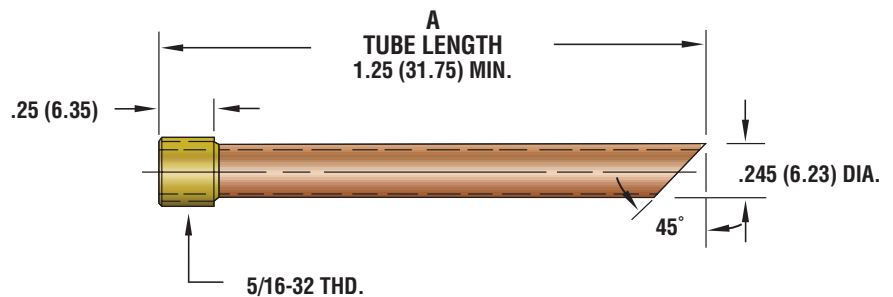

FIGURE 7-4 (Material - Copper & Brass)

ITEM NO. CRW-WT-1500

TYPE "E"

(Use with 4 RW Electrodes)

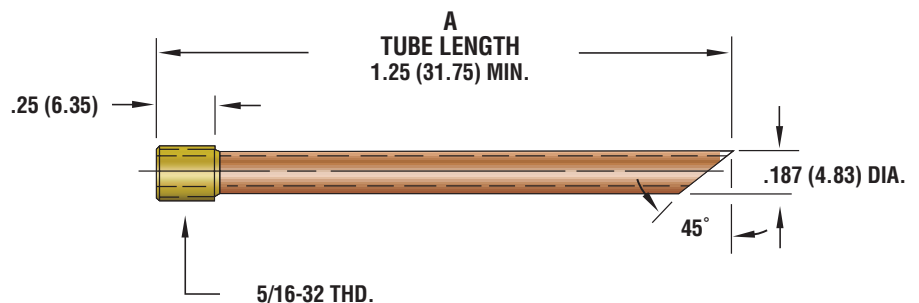

FIGURE 7-5 (Material - Copper & Brass)



Resistance Welding Machine & Accessory

Voice: 269-428-4770 Fax: 269-428-4796

Express Orders: 800-915-9353

Visit Our Website at: [www.resweld.com](http://www.resweld.com)

# WATER TUBES

**ITEM NO. CRW-WT-1600**

**TYPE "F"**

B = .210 (5.31) DIA.

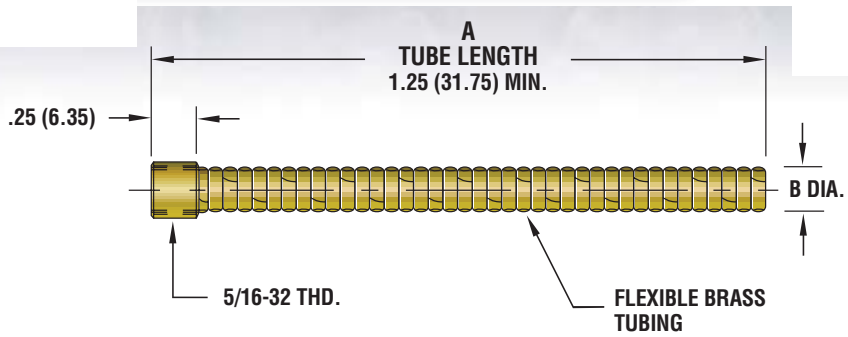

**ITEM NO. CRW-WT-1700**

**TYPE "G"**

B = .250 (6.35) DIA.

FIGURE 7-6 (Material - Interlocked Flexible Brass)

**ITEM NO. CRW-WT-1800**

**TYPE "H"**

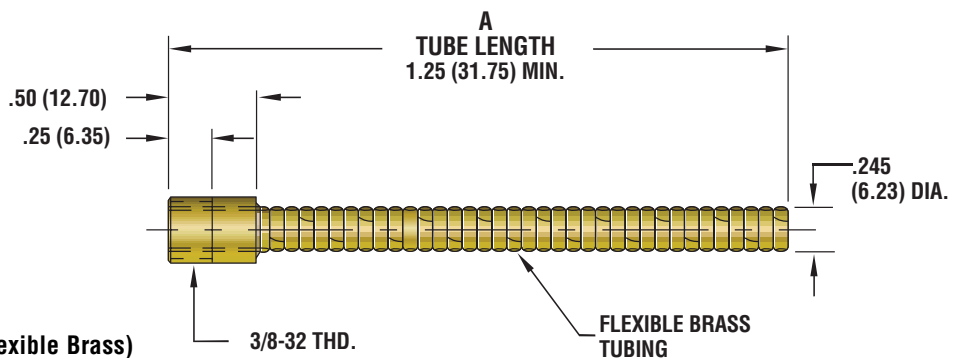

FIGURE 7-7 (Material - Interlocked Flexible Brass)

**ITEM NO. CRW-WT-1900**

**TYPE "I"**

*(Use with 5, 6 & 7 RW Electrodes)*

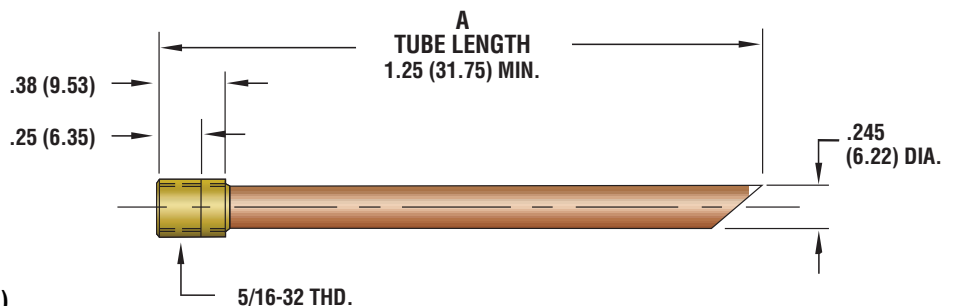

FIGURE 7-8 (Material - Copper & Brass)

**ITEM NO. CRW-WT-2000**

**TYPE "J"**

*(Use with 5, 6 & 7 RW Electrodes)*

FIGURE 7-9 (Material - Copper & Brass)

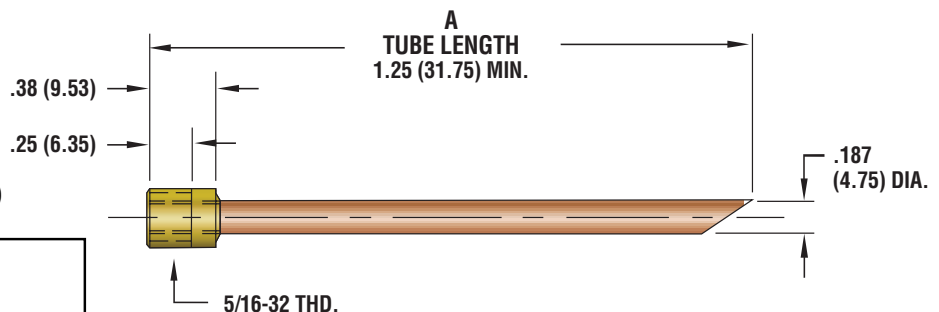

• Dimensions Shown Are: inches (mm).

**PART NUMBER CODING**

- Indicate Desired Tube Length "A" - In .12 (3.18) Increments

**EXAMPLE: TYPE "G" WITH 1.50 (38.10) LENGTH**  
**CRW-WT-1700-12**

Item No. \_\_\_\_\_ "A" Length \_\_\_\_\_



**Resistance Welding Machine & Accessory**

Voice: 269-428-4770 Fax: 269-428-4796

Express Orders: 800-915-9353

Visit Our Website at: [www.resweld.com](http://www.resweld.com)